

## ADAPTERS

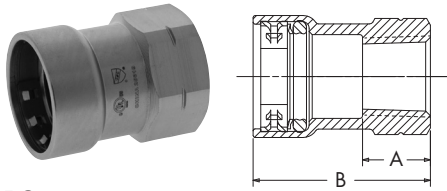

PC203  
Adapter P x F – Carbon Steel

NOM. SIZE	APPROX. NET WT./LBS.	DIM. A INCHES	DIM. B INCHES
1/2	.234	.73	1.83
3/4	.360	.83	1.97
3/4 x 1/2	.380	.83	1.97

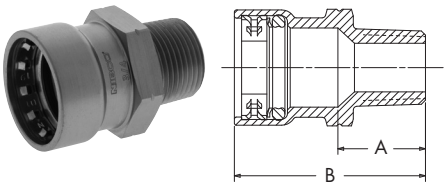

PC204  
Adapter P x M – Carbon Steel

NOM. SIZE	APPROX. NET WT./LBS.	DIM. A INCHES	DIM. B INCHES
1/2	.206	.98	2.09
3/4	.338	1.06	2.20
1	.460	1.14	2.52
1 1/4	.975	2.17	4.02
1 1/2	1.167	2.27	4.20
2	1.615	2.31	4.32

## CAPS

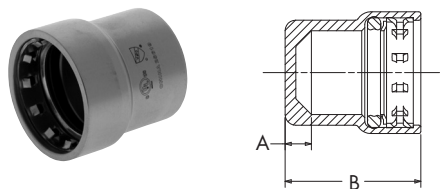

PC217  
Cap P – Carbon Steel

NOM. SIZE	APPROX. NET WT./LBS.	DIM. A INCHES	DIM. B INCHES
1/2	.173	.30	1.40
3/4	.258	.36	1.50
1	.370	.33	1.71
1 1/4	.559	.73	2.58
1 1/2	.729	.85	2.78
2	.952	.81	2.81

## COUPLINGS

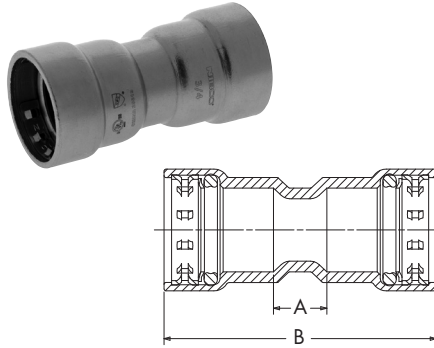

PC200  
Coupling P x P – Carbon Steel

NOM. SIZE	APPROX. NET WT./LBS.	DIM. A INCHES	DIM. B INCHES
1/2	.274	.61	2.81
3/4	.371	.80	3.09
1	.548	.61	3.36
1 1/4	.916	.76	4.46
1 1/2	1.202	.88	4.74
2	1.479	.84	4.86

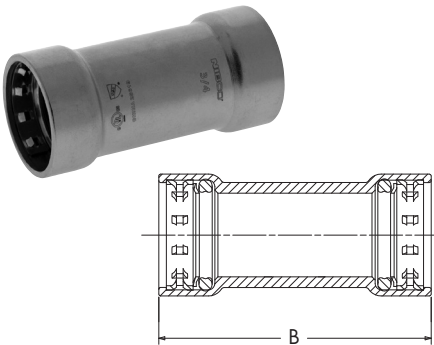

PC201 (No Stop)  
Repair Coupling P x P – Carbon Steel

NOM. SIZE	APPROX. NET WT./LBS.	DIM. B INCHES
1/2	.260	2.81
3/4	.349	3.09
1	.544	3.36
1 1/4	.934	4.46
1 1/2	1.180	4.74
2	1.453	4.86

## ELBOWS

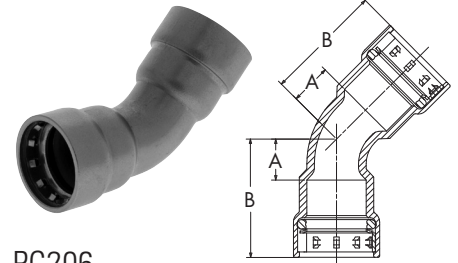

PC206  
45° Elbow P x P – Carbon Steel

NOM. SIZE	APPROX. NET WT./LBS.	DIM. A INCHES	DIM. B INCHES
1/2	.234	.63	1.73
3/4	.427	.75	1.89
1	.669	.89	2.26
1 1/4	1.015	.99	2.84
1 1/2	1.384	1.13	3.06
2	1.871	1.33	3.33

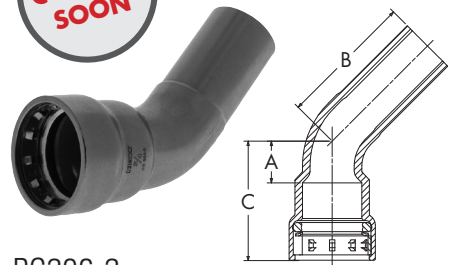

PC206-2  
45° Elbow Ftg x P – Carbon Steel

NOM. SIZE	APPROX. NET WT./LBS.	DIM. A INCHES	DIM. B INCHES	DIM. C INCHES
1/2	.300	.64	1.97	1.74
3/4	.408	.75	2.13	1.89
1	.663	.89	2.52	2.27
1 1/4	1.020	.99	2.99	2.84
1 1/2	1.327	1.13	3.07	3.06
2	1.898	1.33	3.62	3.33

Visit our website for the most current information.

## ELBOWS (Cont.)

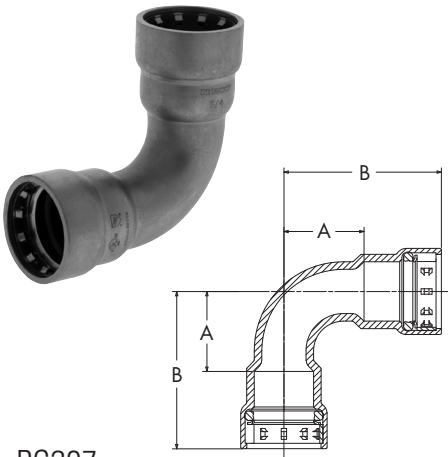

PC207  
90° Elbow P x P – Carbon Steel

NOM. SIZE	APPROX. NET WT./LBS.	DIM. A INCHES	DIM. B INCHES
1/2	.392	1.20	2.30
3/4	.534	1.40	2.54
1	1.307	1.75	3.13
1 1/4	1.230	2.01	3.86
1 1/2	1.712	2.27	4.20
2	2.436	2.81	4.81



PC207-2  
90° Elbow Ftg x P – Carbon Steel

NOM. SIZE	APPROX. NET WT./LBS.	DIMENSIONS INCHES		
		A	B	C
1/2	.361	1.17	2.56	2.65
3/4	.431	1.50	2.80	2.27
1	.807	1.70	3.39	3.08
1 1/4	1.228	2.04	4.04	3.89
1 1/2	1.765	2.34	4.21	4.27
2	1.933	2.79	5.08	4.80

## TEES

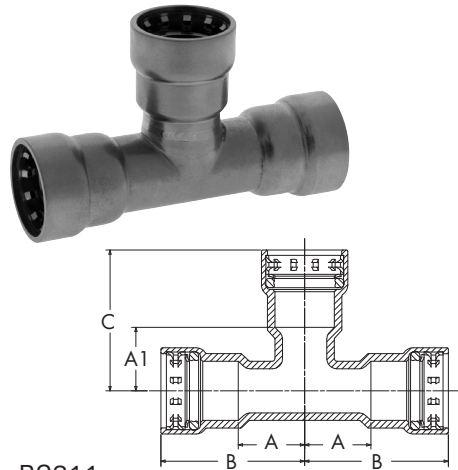

PC211  
Tee P x P x P – Carbon Steel

NOM. SIZE	APPROX. NET WT. LBS.	DIMENSIONS INCHES			
		A	B	C	A1
1/2	.417	1.00	2.10	2.06	.96
3/4	.416	1.15	2.29	2.27	1.13
3/4 x 3/4 x 1/2	.537	1.15	2.29	2.20	1.10
1	1.040	1.26	2.63	2.63	1.26
1 x 1 x 1/2	.940	1.26	2.63	2.33	1.23
1 x 1 x 3/4	.991	1.26	2.63	2.42	1.28

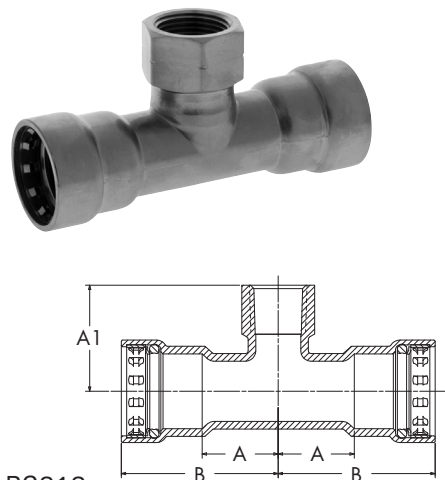

PC212  
Tee P x P x F – Carbon Steel

NOM. SIZE	APPROX. NET WT. LBS.	DIMENSIONS INCHES		
		A	B	A1
3/4	.681	1.15	2.29	1.58
3/4 x 3/4 x 1/2	.740	1.15	2.29	1.55

Visit our website for the most current information.